

**Operating Instructions**  
Original Operating Instructions

## Microsart<sup>®</sup> Manifold

Vacuum Filtration System for the Microbiological Quality Control of Liquid Samples





# Contents

<b>1</b>	<b>About these Instructions</b> . . . . .	6
1.1	Scope . . . . .	6
1.2	Accompanying Documents . . . . .	7
1.3	Target Groups . . . . .	7
1.4	Symbols Used . . . . .	8
1.4.1	Warnings in Operating Instructions . . . . .	8
1.4.2	Other Symbols . . . . .	8
<b>2</b>	<b>Safety Precautions</b> . . . . .	9
2.1	Intended Use . . . . .	9
2.2	Personnel Qualification . . . . .	9
2.3	Significance of these Instructions . . . . .	10
2.4	Proper Working Order of the Product . . . . .	10
2.5	Action in the Event of an Emergency . . . . .	10
2.6	Accessories, Consumables, and Spare Parts . . . . .	11
<b>3</b>	<b>Product Description</b> . . . . .	12
3.1	Product Overview . . . . .	12
3.1.1	Structure of 1-way 3-way 6-way Manifold . . . . .	13
3.1.2	Structure of 2-way Round Arch Manifold . . . . .	14
3.1.3	Base Support (for Manifold and Round Arch Manifold) . . . . .	15
3.2	Filtration through the Vacuum . . . . .	15
<b>4</b>	<b>Installation</b> . . . . .	16
4.1	Scope of Delivery . . . . .	16
4.1.1	Microsart® Manifolds for Microsart® Funnels and Microsart® @filter . . . . .	16
4.1.2	Microsart® Manifolds for Biosart® 100 Monitors . . . . .	16
4.1.3	Microsart® Manifolds for Biosart® 250 Funnel . . . . .	17
4.1.4	Microsart® Manifolds for 100 ml Stainless-steel Funnel . . . . .	17

4.1.5	Microsart® Manifolds for 500 ml Stainless-steel Funnel .....	18
4.2	Selecting an Installation Site .....	19
4.3	Unpacking.....	20
4.4	Installing the Product .....	20
<b>5</b>	<b>Getting Started.....</b>	<b>21</b>
5.1	Integration of the Microsart® Manifold in the Process Structure .....	21
<b>6</b>	<b>Operation.....</b>	<b>22</b>
6.1	Preparing the Process .....	22
6.1.1	Preparing the Base Support (When Using Microsart® @filters) ..	22
6.1.2	Preparing the Base Support (When Using Biosart® 100) .....	22
6.1.3	Preparing the Base Support (When Using Stainless-Steel Funnels, the Microsart® Funnel and Biosart® 250) .....	23
6.2	Starting the Process.....	23
6.3	Finishing the Process.....	24
6.4	Repositioning the Process Structure .....	24
6.4.1	Fitting the Cover Cap.....	24
6.4.2	Removing the Cover Cap.....	25
6.4.3	Attaching the Hose and Hose Coupling.....	25
6.4.4	Removing the Hose .....	25
6.4.5	Connecting Two Manifolds .....	26
6.4.6	Disconnecting Two Manifolds.....	26
6.4.7	Removing the Base Support .....	27
6.4.8	Attaching the Base Support .....	27
<b>7</b>	<b>Cleaning and Maintenance.....</b>	<b>28</b>
7.1	Cleaning Product Surfaces .....	28
7.2	Maintenance Schedule .....	28
7.3	Cleaning the Manifold.....	29
7.3.1	Cleaning after each Filtration: .....	29
7.3.2	Cleaning at the End of the Work Day.....	29

7.4	Replacing the O-Rings.....	30
7.5	Greasing the Valve Stopcock .....	30
7.6	Autoclaving Microsart® Manifold (Body) and Base Support .....	32
7.7	Replacing the Silicone Feet.....	32
<b>8</b>	<b>Malfunctions</b> .....	<b>33</b>
<b>9</b>	<b>Decommissioning</b> .....	<b>35</b>
<b>10</b>	<b>Transport</b> .....	<b>35</b>
<b>11</b>	<b>Storage and Shipping</b> .....	<b>36</b>
11.1	Storage .....	36
11.2	Returning the Product and Parts.....	36
<b>12</b>	<b>Disposal</b> .....	<b>37</b>
12.1	Information on Decontamination .....	37
<b>13</b>	<b>Technical Data</b> .....	<b>38</b>
13.1	Dimensions and Weights.....	38
13.2	Connections and Hoses.....	38
13.3	Permitted Operating Pressure.....	39
13.4	Sterilization .....	39
13.5	Ambient Conditions at the Installation Site .....	40
13.6	Materials.....	40
13.7	Approved Cleaning Agents .....	41
<b>14</b>	<b>Sartorius Service</b> .....	<b>42</b>
<b>15</b>	<b>Accessories, Consumables, and Spare Parts</b> ...	<b>43</b>
15.1	Accessories .....	43
15.2	Consumables.....	43
15.2.1	Microsart® Funnels .....	43
15.2.2	Microsart® @filter, 100 ml .....	44
15.2.3	Microsart® @filter, 250 ml .....	45
15.2.4	Biosart® 100 Monitors .....	46
15.2.5	Biosart® 250 Funnels .....	47
15.2.6	Membrane Filters.....	47
15.3	Spare Parts .....	48

# 1 About these Instructions

## 1.1 Scope

These instructions are part of the product. These instructions apply to the product in the following versions:

<b>Product for Microsart® funnel and Microsart® @filter units</b>	<b>Model</b>
1-way Microsart® manifold	168M1-MS
2-way Microsart® round arch manifold	168M2-MS
3-way Microsart® manifold	168M3-MS
6-way Microsart® manifold	168M6-MS

<b>Product for Biosart® 100 monitors</b>	<b>Model</b>
1-way Microsart® manifold	168M1-BS100
2-way Microsart® round arch manifold	168M2-BS100
3-way Microsart® manifold	168M3-BS100
6-way Microsart® manifold	168M6-BS100

<b>Product for Biosart® 250 funnel</b>	<b>Model</b>
1-way Microsart® manifold	168M1-BS250
3-way Microsart® manifold	168M3-BS250
6-way Microsart® manifold	168M6-BS250

<b>Product with 100 ml stainless-steel funnels</b>	<b>Model</b>
1-way Microsart® manifold	168M1-SS100
3-way Microsart® manifold	168M3-SS100
6-way Microsart® manifold	168M6-SS100

<b>Product with 500 ml stainless-steel funnels</b>	<b>Model</b>
1-way Microsart® manifold	168M1-SS500
3-way Microsart® manifold	168M3-SS500
6-way Microsart® manifold with 500 ml stainless-steel funnels	168M6-SS500

## 1.2 Accompanying Documents

- ▶ In addition to these instructions, observe the following documentation:
  - Operating instructions  
Microsart® e.jet Transfer Pump

## 1.3 Target Groups

These instructions are addressed to the following target groups. The target groups must possess the specified knowledge.

Target group	Knowledge and responsibilities
User	<p>The user is familiar with the operation of the product and the associated work processes. They understand the hazards which may arise when working with the product and know how to prevent them.</p> <p>The user has been trained in the operation of the product.</p>
Laboratory manager	<p>The laboratory manager makes decisions about the use and configuration of the product.</p>
Operator	<p>The product operator is responsible for compliance with safety requirements and workplace safety regulations. The operator must ensure that anyone working with the product has access to the relevant information and is trained to work with the product.</p>

## 1.4 Symbols Used

### 1.4.1 Warnings in Operating Instructions

---

#### **WARNING**

Denotes a danger with the risk that death or severe injury may result if it is **not** avoided.

---

#### **CAUTION**

Denotes a hazard that may result in moderate or minor injury if it is **not** avoided.

---

#### **NOTICE**

Denotes a danger with the risk that property damage may result if it is **not** avoided.

---

### 1.4.2 Other Symbols

- ▶ Required action: Describes actions which must be carried out.
- ▷ Result: Describes the result of the actions carried out.



## 2 Safety Precautions

### 2.1 Intended Use

The product is a manifold. A vacuum filtration system is formed by connecting the manifold to a pump.

You can use this vacuum filtration system in combination with the corresponding membrane filters to inspect a wide range of liquids for microbiological contamination. The manifold is thus a key component in microbiological quality control for liquid samples.

#### Operating Conditions for the Product

The product may only be used indoors. The product may only be used with the equipment and under the operating conditions described in the Technical Data section of these instructions.

The product must be operated with negative pressure. The vacuum source to generate the negative pressure must be suitable for the product (for suitability, see Chapter "13.2 Connections and Hoses", page 38).

#### Modifications to the Product

You must **not** modify or repair the product or make any technical changes. Any retrofitting or technical changes to the product are only permitted with prior written permission from Sartorius.

### 2.2 Personnel Qualification

If persons who do **not** possess sufficient knowledge about safely handling the product are working on the product, those people can injure themselves or others.

- ▶ Ensure that all persons working on the product possess the necessary skills and qualifications (for a description, see Chapter "1.3 Target Groups", page 7).

- ▶ If a particular qualification is required for the tasks described, these tasks must be performed by the required target group.
- ▶ If **no** qualification is required for the tasks described, the tasks can be performed by the target group "User".

## 2.3 Significance of these Instructions

Failure to follow the instructions in this manual can have serious consequences, e.g. exposure of individuals to electrical, mechanical, or chemical hazards.

- ▶ Read the instructions carefully and in full.
- ▶ Ensure that the information contained in these instructions is available to all individuals working with the product.
- ▶ Keep the instructions safe.
- ▶ If these instructions are lost: Request a replacement or download the latest version from the Sartorius website ([www.sartorius.com](http://www.sartorius.com)).

## 2.4 Proper Working Order of the Product

A damaged product or worn parts may lead to malfunctions or cause hazards which are difficult to recognize.

- ▶ Only operate the product when it is safe and in perfect working order.
- ▶ Observe the maintenance and cleaning intervals (for intervals and maintenance tasks, see Chapter "7 Cleaning and Maintenance", page 28).
- ▶ Have any malfunctions or damage repaired immediately by Sartorius Service.

## 2.5 Action in the Event of an Emergency

If there is immediate danger of personal injury or equipment damage, e.g., due to malfunctions or dangerous situations, the product must be immediately taken out of operation.

- ▶ Shut down the vacuum pump.
- ▶ Set the valve stopcock to "Stop".
- ▶ In the event of a malfunction, proceed as per the malfunction table (see Chapter "8 Malfunctions", page 33).

## 2.6 Accessories, Consumables, and Spare Parts

The use of unsuitable accessories, consumables, and spare parts can affect the functionality and safety of the device and have the following consequences:

- Risk of injury to persons
  - Damage to the product
  - Malfunctioning of the product
  - Failure of the product
  - Incorrect test results
  - Loss of the sample to be tested
  - Contamination of the sample to be tested
- 
- ▶ Only use approved accessories, consumables, and spare parts supplied by Sartorius.
  - ▶ Only use accessories, consumables, and spare parts that are in proper working order (see Chapter "15 Accessories, Consumables, and Spare Parts", page 43).

### 3 Product Description

#### 3.1 Product Overview

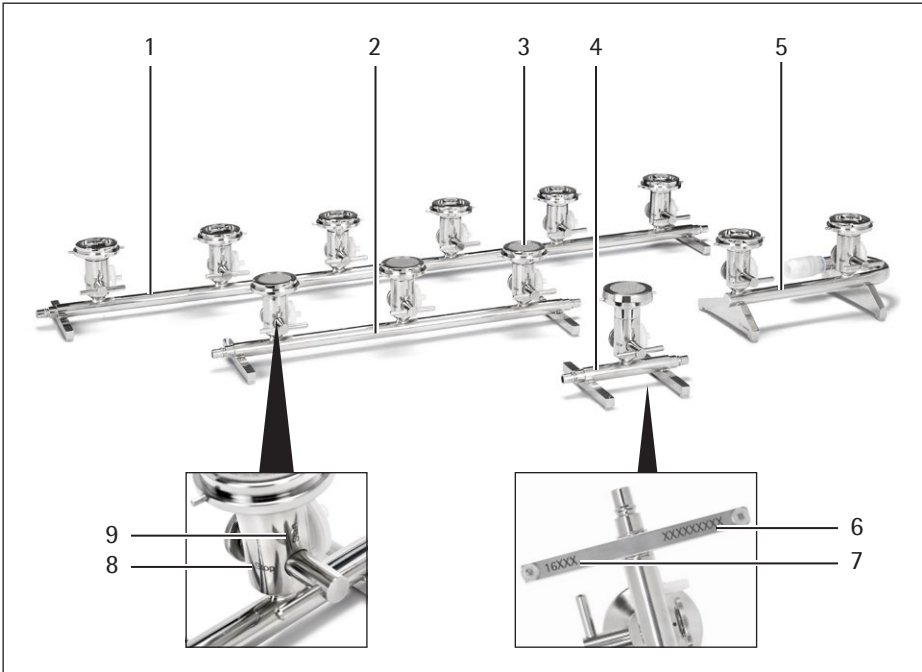

Fig. 1: Microsart® manifolds

No.	Designation
1	6-way manifold
2	3-way manifold
3	Base support with sintered frit
4	1-way manifold

No.	Designation
5	2-way round arch manifold
6	Serial number
7	Distribution number
8	"Stop" position
9	"Start" position

### 3.1.1 Structure of 1-way|3-way|6-way Manifold



Fig. 2: Body of 1-way manifold (example)

No.	Designation
1	Cover cap
2	Knurled screw with flat spring
3	Ventilation hole

No.	Designation
4	Hose with quick-lock coupling
5	Valve stopcock
6	Body of 1-way manifold
7	Silicone foot

### 3.1.2 Structure of 2-way Round Arch Manifold



Fig.3: Body of 2-way round arch manifold

No.	Designation
1	Knurled screw with flat spring
2	Ventilation hole
3	Valve stopcock
4	Connector for adaptation to the Microsart® e.jet pump

No.	Designation
5	Body of 2-way round arch manifold
6	Silicone foot with adjustable stainless-steel housing

### 3.1.3 Base Support (for Manifold and Round Arch Manifold)

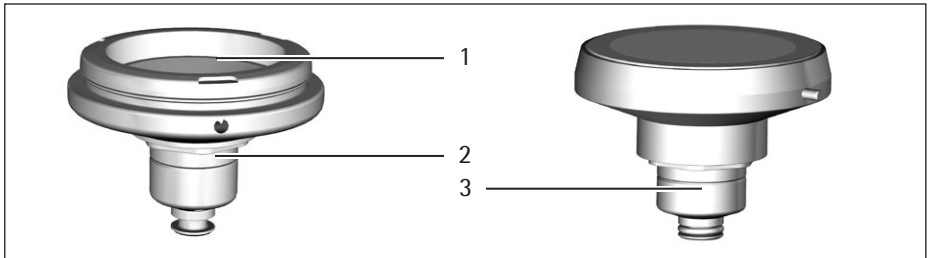

Fig. 4: Base support

No.	Designation	No.	Designation
1	Frit	3	Base support (168M1-BS100 – 168M6-BS250)
2	Base support (168M1-MS – 189M3-MS)		(168M1-BS100 – 168M6-SS500)

## 3.2 Filtration through the Vacuum

The method of membrane filtration enables you to determine the microbiological quality of liquid samples.

By means of filtration, any microorganisms present in the sample are concentrated on the membrane filter in order to then cultivate them on a culture medium.

Reusable stainless-steel funnels and various disposable products can be used on the product in conjunction with a filter membrane. A membrane filter and a funnel with a specific volume must be placed on the suction strip in advance for filtration. In order to filter the liquid sample through the filter, the manifold must first be connected to a vacuum source (Sartorius recommends using a Microsart® e.jet vacuum pump).

## 4 Installation

### 4.1 Scope of Delivery

#### 4.1.1 Microsart® Manifolds for Microsart® Funnels and Microsart® @filter

	Manifolds			
	1-way	2-way	3-way	6-way
Manifold	1	1	1	1
Base support for 47 mm filter	1	2	3	6
Sintered frit	1	2	3	6
Vent filter	1	2	3	6
Cover cap to seal the output	1		1	1
Quick coupling for adapting to the Microsart® e.jet vacuum pump		1		
Silicone hose with quick-lock coupling, 20 cm	1		1	1
Operating instructions	1	1	1	1

#### 4.1.2 Microsart® Manifolds for Biosart® 100 Monitors

	Manifolds			
	1-way	2-way	3-way	6-way
Manifold	1	1	1	1
Base support for 47 mm filter	1	2	3	6
Sintered frit	1	2	3	6
Biosart® adapter	1	2	3	6
Vent filter	1	2	3	6
Cover cap to seal the output	1		1	1
Quick coupling for adapting to the Microsart® e.jet – vacuum pump		1		
Silicone hose with quick-lock coupling, 20 cm	1		1	1
Operating instructions	1	1	1	1



#### 4.1.3 Microsart® Manifolds for Biosart® 250 Funnel

	Manifolds		
	1-way	3-way	6-way
Manifold	1	1	1
Base support for 47 mm and 50 mm filters	1	3	6
Sintered frit	1	3	6
Silicone seal	1	3	6
Plug to seal the ventilation opening	1	3	6
Cover cap to seal the output	1	1	1
Silicone hose with quick-lock coupling, 20 cm	1	1	1
Operating instructions	1	1	1

#### 4.1.4 Microsart® Manifolds for 100 ml Stainless-steel Funnel

	Manifolds		
	1-way	3-way	6-way
Manifold	1	1	1
Base support for 47 mm and 50 mm filters	1	3	6
Sintered frit	1	3	6
Silicone seal	1	3	6
100 ml stainless-steel funnel	1	3	6
Cover (for 100 ml)	1	3	6
Seal (for 100 ml)	1	3	6
Plug to seal the ventilation opening	1	3	6
Cover cap to seal the output	1	1	1
Silicone hose with quick-lock coupling, 20 cm	1	1	1
Operating instructions	1	1	1

#### 4.1.5 Microsart® Manifolds for 500 ml Stainless-steel Funnel

	Manifolds		
	1-way	3-way	6-way
Manifold	1	1	1
Base support for 47 mm and 50 mm filters	1	3	6
Sintered frit	1	3	6
Silicone seal	1	3	6
500 ml stainless-steel funnel	1	3	6
Cover (for 500 ml)	1	3	6
Seal (for 500 ml)	1	3	6
Plug to seal the ventilation opening	1	3	6
Cover cap to seal the output	1	1	1
Silicone hose with quick-lock coupling, 20 cm	1	1	1
Operating instructions	1	1	1

## 4.2 Selecting an Installation Site

► Make sure that the following conditions are met at the installation site:

Condition	Features
Ambient conditions	<ul style="list-style-type: none"> <li>– Suitability tested (see Chapter "13.5 Ambient Conditions at the Installation Site", page 40 for ambient conditions)</li> </ul>
Setup surface	<ul style="list-style-type: none"> <li>– Stable and even surface, as well as sufficient operating height</li> <li>– Sufficient surface area for the product and the peripheral devices (for the product space requirements, see Chapter "13.1 Dimensions and Weights", page 38; for peripheral device space requirements, see instructions for the peripheral devices, see Chapter "1.2 Accompanying Documents", page 7)</li> <li>– Access to a vacuum source and a drain is provided</li> </ul>
Access to parts relevant to operation	Convenient and safe

### 4.3 Unpacking

#### Procedure

- ▶ Unpack the product.
- ▶ If the product is stored temporarily: Observe the storage information (see Chapter "11.1 Storage", page 36).
- ▶ Install the product at the intended installation location.
- ▶ Keep all parts of the original packaging, e.g. to return the product.

### 4.4 Installing the Product

#### Procedure

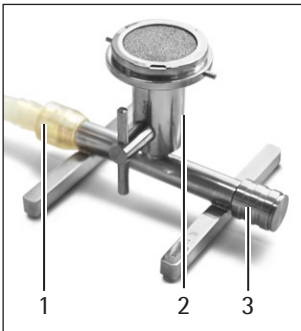

- ▶ Install the following components (as needed) on the ventilation hole (2):
  - The sterile ventilation filter (without touching the filter opening)
 Or:
  - The sealing plug
- ▶ Connect the product to the vacuum source via the hose (1).
- ▶ Turn the valve stopcock to "Stop".
- ▶ Ensure that the filtrate is being properly drained on the pump side.
- ▶ Ensure that the sealing cap (3) is fitted.

## 5 Getting Started

### 5.1 Integration of the Microsart® Manifold in the Process Structure

#### Requirements

- ▶ The product is connected with the vacuum pump (see Chapter "4.4 Installing the Product", page 20).
- ▶ The vacuum pump is switched off.
- ▶ The vacuum pump is connected to the power supply at the installation site.

#### Procedure

- ▶ Place the filtration unit or the filter and funnel (sterile) on the manifold.

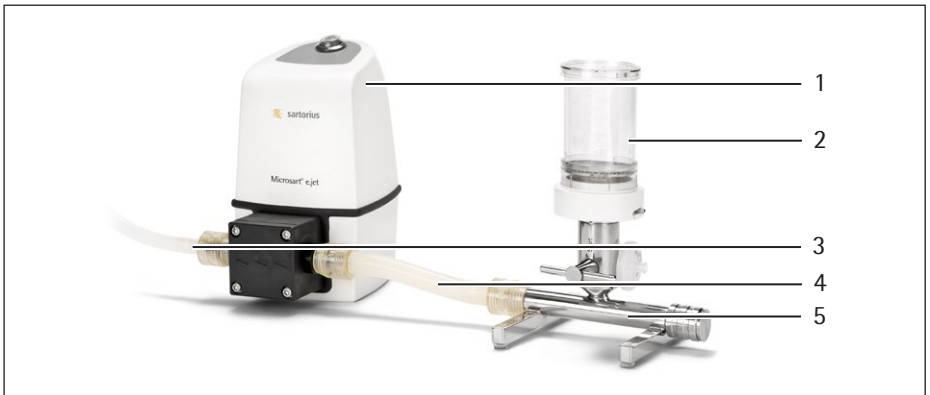

Fig. 5: Process structure for the filtration (in this example, Microsart® 1-way manifold with Biosart® 100)

No.	Designation
1	Vacuum pump (here: Microsart® e.jet)
2	Filtration unit (here: Biosart® 100)
3	Drain hose

No.	Designation
4	Vacuum hose with quick coupling
5	Microsart® 1-way manifold

## 6 Operation

### 6.1 Preparing the Process

#### Procedure

- ▶ Ensure that the base support is decontaminated before the process begins (see Chapter "7.6 Autoclaving Microsart® Manifold (Body) and Base Support", page 32).

#### 6.1.1 Preparing the Base Support (When Using Microsart® @filters)

#### Procedure

- ▶ Removing the sintered frit.
- ▶ Adapt the filtration unit on the base support.



#### 6.1.2 Preparing the Base Support (When Using Biosart® 100)

#### Procedure

- ▶ Mount the filtration unit Biosart® 100 to the base support with an adapter.



### 6.1.3 Preparing the Base Support (When Using Stainless-Steel Funnels, the Microsart® Funnel and Biosart® 250)

#### Procedure

- ▶ Remove the sterile membrane filter from the packaging using tweezers.
- ▶ Carefully use tweezers to place the membrane filter on the base support with the grid facing upward.
- ▶ Place the funnel (1) on the base support (3) and fix it to the pins provided using the bracket (2).
- ▶ When using the **Biosart® 250**, place the funnel on the base support and connect to the pins by gently turning it to the right.
- ▶ When using the Microsart Funnel, apply the funnel to the base support after applying the membrane filter.

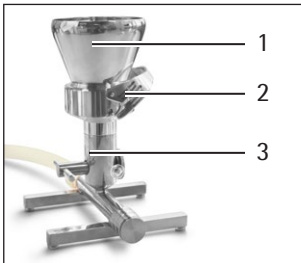

## 6.2 Starting the Process

#### Procedure

- ▶ Switch on the vacuum pump.
- ▶ Fill the liquid sample into the filtration unit or the funnel (depending on application).
- ▶ Set the valve stopcock to the "Start" position.



## 6.3 Finishing the Process

### Procedure

- ▶ After fully vacuuming the liquid sample (filtration unit or funnel no longer contains liquid), turn the valve stopcock back to the "Stop" position.
- ▶ Remove the membrane filter with tweezers and transfer it to a corresponding culture medium.

## 6.4 Repositioning the Process Structure

### Procedure

- ▶ Finish the process (see Chapter "6.3 Finishing the Process", page 24)
- ▶ Clean the components (see Chapter "7 Cleaning and Maintenance", page 28)
- ▶ Fit the filtration unit / funnel according to the process specifications (see Chapter "6.1 Preparing the Process", page 22).

### 6.4.1 Fitting the Cover Cap

#### Procedure

- ▶ Place the cover cap (1) on the lateral opening of the manifold and adapt it by lightly pressing with the plug-in nipple.

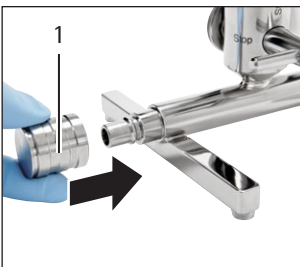



### 6.4.2 Removing the Cover Cap

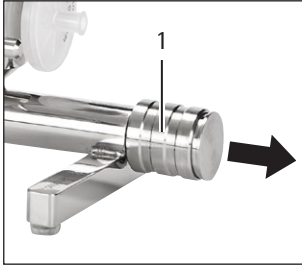

#### Procedure

- ▶ With your thumb on the front face, push the cover cap towards the connector (1) and pull back the outer sleeve of the connector with your index and middle fingers.
- ▶ Then release your thumb and remove the cap from the connector.

### 6.4.3 Attaching the Hose and Hose Coupling

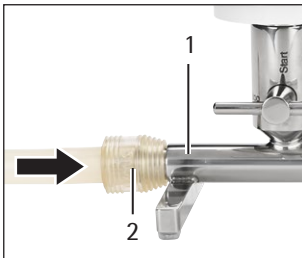

#### Procedure

- ▶ Fix the manifold (1) with one hand and use the other hand to connect the quick coupling (2) with the hose to the manifold plug-in nipple.

### 6.4.4 Removing the Hose

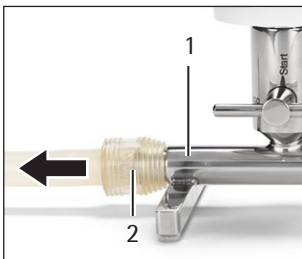

#### Procedure

- ▶ Hold the manifold (1) with one hand and use the other hand to pull the hose with the quick coupling (2) from the manifold connector.

### 6.4.5 Connecting Two Manifolds

When processing a large number of samples, two manifolds can be connected to each other using a connection coupling in order to increase the filtration capacity.

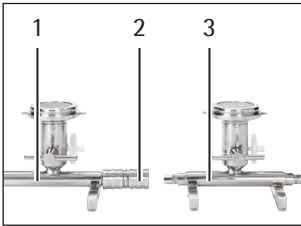

#### Procedure

- ▶ Hold the first manifold (1).
- ▶ Push the connection coupling (2) onto the connector until the stop.
- ▶ Hold the first manifold with the attached connection coupling.
- ▶ Push the second manifold (3) with the connector onto the connection coupling until the stop.

### 6.4.6 Disconnecting Two Manifolds

#### Procedure

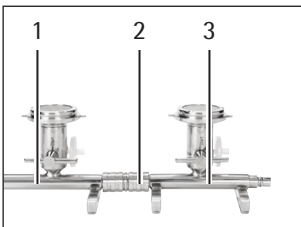

- ▶ Hold the first manifold (1) at the connection coupling (2).
- ▶ Pull the second manifold (3) from the connector. At the same time, pull back the case of the connection coupling in order to disengage the connection.
- ▶ Hold the first manifold (1). Hold the connection coupling (2).
- ▶ Pull out the connection coupling (2). At the same time, pull back the case of the connection coupling in order to disengage the manifold from the connection coupling.

### 6.4.7 Removing the Base Support

Remove the sintered frits for cleaning purposes. The base support can also be removed for maintenance purposes.

#### Procedure

- ▶ Hold the manifold at the drain pipe of the manifold (2).
- ▶ Lift out the base support (1).

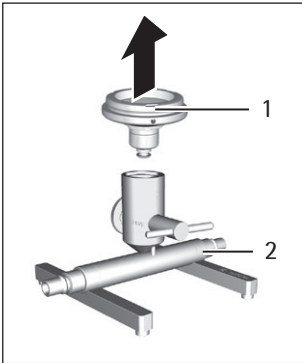

### 6.4.8 Attaching the Base Support

#### Procedure

- ▶ Place the base support (1) in the manifold (2)
- ▶ Use a rotary movement to check if the base support has engaged.
- ▶ The base support can be engaged in three different positions with the pins (3). This may be required when using bayonet-connection attachments.

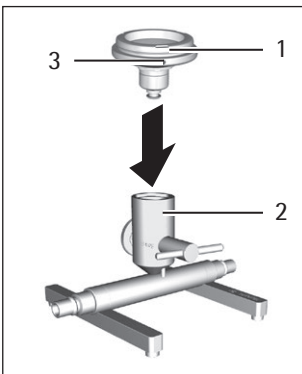

## 7 Cleaning and Maintenance

### 7.1 Cleaning Product Surfaces

#### Requirements

The process is complete (see Chapter "6.3 Finishing the Process", page 24).

#### Procedure

- ▶ Disconnect the product from the vacuum pump.
- ▶ **NOTICE** Corrosion or damage to the product due to unsuitable cleaning agents!
  - ▶ Do not use corrosive, chloride-containing or aggressive cleaning agents.
  - ▶ Do not use cleaning agents that contain abrasive ingredients, e.g. scouring agents, steel wool.
  - ▶ Do not use any solvent-based cleaning agents.
  - ▶ Only use suitable cleaning agents (for materials, see Chapter "13.7 Approved Cleaning Agents", page 41) and observe the product information for the cleaning agent used.
- ▶ Wipe the product housing with a damp cloth. Use a mild soapy solution or a suitable cleaning agent for more severe contaminations.

### 7.2 Maintenance Schedule

Interval	Component	Action	Chapter, page
Daily	Manifold	Remove any product residues from the manifold and rinse it with disinfectant and then sterile water.	7.3, 29
		Empty the manifold with care.	7.3, 29
Weekly	Valve stopcock	Grease the valve stopcock.	7.5, 30
	Vent filter	Insert the new vent filter.	4.4, 20

<b>Interval</b>	<b>Component</b>	<b>Action</b>	<b>Chapter, page</b>
Weekly / depending on application	Manifold	Autoclave the manifold.	7.6, 32
Annually	O-ring	The O-rings shift.	7.4, 30
Only in the event of leakage / damage	Silicone foot	Replace the silicone feet.	7.7, 32

## 7.3 Cleaning the Manifold

### 7.3.1 Cleaning after each Filtration:

#### Procedure

- ▶ Spray the base support with disinfectant or fill up to a few milliliters.
- ▶ Vacuum out the disinfectant.
- ▶ Rinse the manifold with sterile water.

### 7.3.2 Cleaning at the End of the Work Day

#### Procedure

- ▶ Spray the base support with disinfectant or fill up to a few milliliters.
- ▶ Allow the disinfectant to take effect for 3 – 5 minutes.
- ▶ Vacuum out the disinfectant.
- ▶ Rinse the manifold with sterile water.
- ▶ Empty the manifold by tipping it (see Chapter “9 Decommissioning”, page 35).
- ▶ Dry the sintered frits using lab cloths.

## 7.4 Replacing the O-Rings

### Procedure

- ▶ Remove the base support (see Chapter "6.4.7 Removing the Base Support", page 27).

### Notice

The O-ring is damaged by improper use. Only replace the O-ring using a suitable tool and avoid any damage.

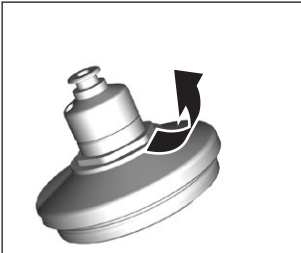

- ▶ Carefully remove the O-ring from the base support groove.
- ▶ Insert the O-ring and make sure that it is fully inserted.

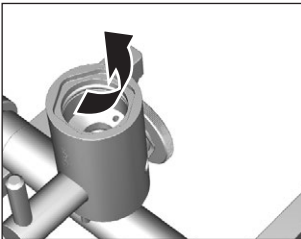

- ▶ Carefully remove the O-ring from the groove.
- ▶ Insert the O-ring and make sure that it is fully inserted.

## 7.5 Greasing the Valve Stopcock

### Procedure

- ▶ Remove the ventilation filter (4) or the blind plug.
- ▶ Fit the valve stopcock (1) with your left hand and screw in the knurled screw (3) counterclockwise.
- ▶ Pull the valve stopcock out frontward from the manifold (2).

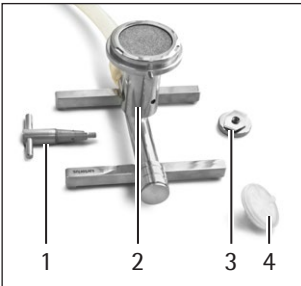

## Cleaning the Valve Stopcock

### Procedure

- ▶ Clean the valve stopcock using a clean cloth.
- ▶ Ensure that the contact surfaces are clean and free from particles.
- ▶ Grease the valve stopcock on the contact surface using new high-vacuum grease.

## Inserting the Valve Stopcock

### Procedure

- ▶ Insert the valve stopcock into the manifold until the rear stop. The handle's thinner, shorter side must point toward the left.

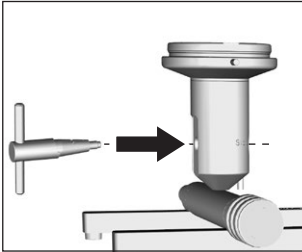

- ▶ Fit the valve stopcock with your left hand, and use your right hand to install the knurled screw with spring in such a way that the spring is vertical, or that the spring is in the groove of the manifold.



## 7.6 Autoclaving Microsart® Manifold (Body) and Base Support

### Procedure

- ▶ Remove the ventilation filter or blind plug.
- ▶ Strip down the Microsart® manifold system:
  - ▶ Remove the filtration unit.
  - ▶ Remove all hoses.
- ▶ Autoclave the manifold with base support.

## 7.7 Replacing the Silicone Feet

### Procedure

- ▶ Turn the manifold upside down.
- ▶ Unscrew the screw (1) on the silicone foot using a screwdriver.
- ▶ Remove the washer (2).
- ▶ Position a new silicone foot (3).
- ▶ Insert the washer and screw and tighten until the silicone foot begins to arch upward.

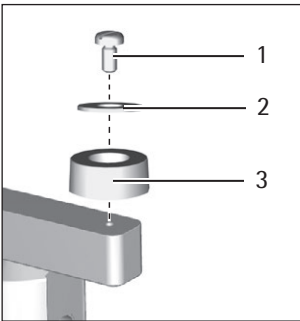



## 8 Malfunctions

### Process Malfunctions

Malfunction	Cause	Remedy	Chapter, page
The filtration time increases significantly.	There is a leak.	The O-rings shift.	7.4, 30
The liquid is <b>not</b> vacuumed despite the stopcock being set to "Start".	There is a leak.	<p>Ensure that the cover cap is attached.</p> <p>Ensure that the quick coupling incl. vacuum hose is properly connected to the pump / manifold.</p> <p>In addition, check if all base supports are firmly adapted on the manifold and that all valve stopcocks fit firmly.</p> <p>If the valve stopcock has stress marks, contact Sartorius Service.</p>	6.4.1, 24
The Microsart® manifold is not stable and tips over.	One or more silicone feet are damaged or missing.	Affix a new silicone foot incl. washer and screw.	7.7, 32

<b>Malfunction</b>	<b>Cause</b>	<b>Remedy</b>	<b>Chapter, page</b>
The valve stopcock is too slack in the longitudinal axis or sits too loosely in the matching piece.	The knurled screw is not fully screwed in, the flat spring is bent or not placed in the corresponding recess or the valve stopcock is not aligned with the smaller, narrower marking end.	Fully tighten the knurled screw or replace the knurled screw incl. the flat spring. Correctly align the valve stopcock.	7.5, 30: Inserting the valve stopcock
Moving the valve stopcock is not possible; a high amount of force must be used for the rotation.	The valve stopcock is not sufficiently lubricated and may have integrated somewhat into the matching piece.	Grease the valve stopcock. If the malfunction reoccurs: Contact Sartorius Service.	7.5, 30
The valve stopcock cannot be rotated by 360°.	The Socket screw in the Microsart® body is not set correctly.	Contact Sartorius Service.	

## 9 Decommissioning

### Requirements

The process is complete (see Chapter "6.3 Finishing the Process", page 24)



### Procedure

- ▶ Empty the manifold with the aid of the vacuum:
  - ▶ Open the valve stopcock (set to "start").
  - ▶ Tip the manifold while the pump is still in operation.
  - ▶ Vacuum until the manifold is completely emptied.
- ▶ Switch off the vacuum pump.
- ▶ Set the stopcock to "Stop".
- ▶ Detach the manifold from the vacuum pump.
- ▶ Remove all accessories from the product.
- ▶ Remove the hose with connector.
- ▶ Clean the manifold (see Chapter "7.1 Cleaning Product Surfaces", page 28).

## 10 Transport

- ▶ Clean and disinfect (see Chapter "7 Cleaning and Maintenance", page 28) the manifold after it has been decommissioned (see Chapter "9 Decommissioning", page 35).
- ▶ Sartorius recommends carrying out the internal transport of the manifold in the original packaging. The original packaging can be requested from Sartorius.

# 11 Storage and Shipping

## 11.1 Storage

### Procedure

- ▶ If the product is in operation:
  - ▶ Decommission the product.
  - ▶ Properly clean and dry the product.
- ▶ Store the product according to the ambient conditions (see Chapter "13.5 Ambient Conditions at the Installation Site", page 40).

## 11.2 Returning the Product and Parts

Defective products or parts can be sent back to Sartorius. Returned products must be clean, decontaminated, and packed in their original packaging.

Transport damage as well as measures for subsequent cleaning and disinfection of the product or parts by Sartorius shall be charged to the sender.

---

### **WARNING**

#### **Risk of injury due to contaminated products.**

Products contaminated with hazardous materials [nuclear, biological, or chemical (NBC)] will **not** be accepted for repair or disposal.

- ▶ Observe the information on decontamination (see Chapter "12.1 Information on Decontamination", page 37).
- 

### Procedure

- ▶ Decommission the product.
- ▶ Contact Sartorius Service for instructions on how to return products or parts (please refer to our website at [www.sartorius.com](http://www.sartorius.com) for return instructions).
- ▶ Pack the product and its parts in their original packaging for return.

## 12 Disposal

### 12.1 Information on Decontamination

The device does **not** contain any hazardous materials that would necessitate special disposal actions.

Contaminated samples used during the process are potentially hazardous materials that could cause biological or chemical hazards.

If the device has come into contact with hazardous substances: Steps must be taken to ensure proper decontamination and declaration. The operator is responsible for adhering to local government regulations on the proper declaration for transport and disposal and the proper disposal of the device.

---

 **WARNING**

**Risk of injury due to contaminated products.**

Products contaminated with hazardous materials (NBC contamination) will **not** be accepted by Sartorius for repair or disposal.

---

## 13 Technical Data

### 13.1 Dimensions and Weights

	Unit	Value
Dimensions (L x W x H)		
Microsart® 1-way stainless-steel manifold	mm	176 x 120 x 98
Microsart® 2-way round arch manifold	mm	246 x 130 x 118
Microsart® 3-way stainless-steel manifold	mm	474 x 120 x 98
Microsart® 6-way stainless-steel manifold	mm	924 x 120 x 98
Weights		
Microsart® 1-way stainless-steel manifold	kg	0.82 – 1.20 (depending on design)
Microsart® 2-way round arch manifold	kg	1.65
Microsart® 3-way stainless-steel manifold	kg	2.10 – 3.80 (depending on design)
Microsart® 6-way stainless-steel manifold	kg	4.00 – 7.40 (depending on design)

### 13.2 Connections and Hoses

	Unit	Value
Microsart® 1-way / 3-way / 6-way stainless-steel manifold		
Quick seal, including cap, coupling with hose nozzle and hose		

	Unit	Value
Microsart® 2-way stainless-steel manifold		
Quick seal to connect to a Microsart® e.jet pump 166MP-4		
Permitted hoses		
Type: Silicone hose		
Outer diameter (OD)	mm	15
Inner diameter (ID)	mm	7

### 13.3 Permitted Operating Pressure

	Unit	Value
Maximum operating pressure		
Only operate under vacuum	mbar abs.	0 – 1000
Recommended vacuum pump		
Microsart® e.jet pump		

### 13.4 Sterilization

	Unit	Value
Autoclaving		
Temperature, max.	°C	134
Duration, max.	h	0.5
Dry heat		
Temperature, max.	°C	150
Duration, max.	h	2.5

### 13.5 Ambient Conditions at the Installation Site

	Unit	Value
Installation site: Conventional laboratory rooms, max. height above sea level	m	4000
Temperature	°C	+5 – +40
Relative humidity		
At temperatures of up to 31°C	%	80
Decreasing linearly at temperatures from 31°C to 40°C	%	50

### 13.6 Materials

Stainless steel 1.4404

All stainless-steel components (parts which come into contact with the product / except stainless steel funnels, sintered frits and cover caps)

Stainless steel 1.4539

Sintered frit

Stainless steel 1.4571

Cover cap\*

Stainless steel 1.4301

100 ml / 500 ml stainless-steel funnel incl. cover\*\*

Fluorinated rubber (FR)

O-ring (body)

Monel (nickel-copper alloy)

Valve stopcock

Polypropylene (PP)

Vent filter\*\*

Dummy plugs\*\*

Biosart® Adapter\*\*



Polysulfone (PSU)
Coupling with hose nozzle*
Polyvinylidene fluoride (PVDF)
Connector***
Silicone
Gasket**
Seal in Biosart Adapter**
Seal for funnel cover**
O-ring (connector)**
O-ring (base support)
Hose
Silicone foot

\* **Not** for the 2-way round arch manifold

\*\* **Not** all manifold variants

\*\*\* **Only** for the 2-way round arch manifold

### 13.7 Approved Cleaning Agents

	Unit	Value
Ethanol solution	%	70
Isopropyl alcohol solution	%	70
Meliseptol <sup>®</sup> rapid*		
perform <sup>®</sup> advanced alcohol EP**		

\* Meliseptol<sup>®</sup> rapid is a registered trademark of B. Braun Melsungen AG

\*\* perform<sup>®</sup> advanced alcohol EP is a registered trademark of Schülke & Mayr AG

## 14 Sartorius Service

Sartorius Service is available for queries regarding the product. Please visit the Sartorius website ([www.sartorius.com](http://www.sartorius.com)) for information about the service addresses, services provided, or to contact a local representative.

When contacting Sartorius Service with questions about the system or in the event of malfunctions, be sure to have the product information, e.g. serial number, close at hand. This information can be found on the manufacturer's ID label.

## 15 Accessories, Consumables, and Spare Parts

### 15.1 Accessories

This table contains an excerpt of the accessories that can be ordered. For information on other products, contact Sartorius.

Item	Order number
Minisart® SRP25, vent filter	17575-----ACK
Quick coupling, for connection to two manifolds	168ZA-C0001
Vacuum hose, silicone, with quick-lock coupling, 1 m	1ZA---0006
Hose, pressure side with quick-lock coupling	
1 m	1ZAS--0007
2 m	1ZAS--0019
10 m	1ZAS--0020
Stainless-steel adapter for adapting the polycarbonate filter holder and stainless-steel adapter (glass filter holder)	168ZA-D0001

### 15.2 Consumables

The different bases for the base support are listed here as consumables:

These tables contain excerpts of the consumables that can be ordered. For information on other products, contact Sartorius.

#### 15.2.1 Microsart® Funnels

Item	Order number
Microsart® Funnel 100, sterile	16A07--10-----N
Microsart® Funnel 250, sterile	16A07--25-----N

### 15.2.2 Microsart® @filter, 100 ml

These tables contain excerpts of the consumables that can be ordered. For information on other products, contact Sartorius.

Item	Order number
Microsart® @filter, 100 ml, with cellulose nitrate membrane filter, white with black grid, 0.45 µm, in bags	6D01--10-06--BL
Microsart® @filter, 100 ml, with cellulose nitrate membrane filter, white with black grid, 0.2 µm, in bags	16D01--10-07--BL
Microsart® @filter, 100 ml, with cellulose nitrate membrane filter, white with black grid, 0.45 µm high flow, in bags	16D01--10-H6--BL
Microsart® @filter, 100 ml, with cellulose nitrate membrane filter, green with dark green grid, 0.45 µm, in bags	16D02--10-06--BL
Microsart® @filter, 100 ml, with cellulose nitrate membrane filter, gray with white grid, 0.45 µm high flow, in bags	16D03--10-H6--BL
Microsart® @filter, 100 ml, with regenerated cellulose membrane, white, 0.45 µm, in bags	16D05--10-06--BL
Microsart® @filter, 100 ml, with polycarbonate filter, white, 0.45 µm, in bags	16D06--10-06--BL
Microsart® @filter, 100 ml, with cellulose nitrate membrane filter, white with black grid, 0.2 µm, single sterile	16D01--10-07-ACG
Microsart® @filter, 100 ml, with cellulose nitrate membrane filter, white with black grid, 0.45 µm high flow, single sterile	16D01--10-H6-ACG
Microsart® @filter, 100 ml, with cellulose nitrate membrane filter, gray with white grid, 0.45 µm high flow, single sterile	16D03--10-H6-ACG

### 15.2.3 Microsart® @filter, 250 ml

These tables contain excerpts of the consumables that can be ordered. For information on other products, contact Sartorius.

Item	Order number
Microsart® @filter, 250 ml, with cellulose nitrate membrane filter, white with black grid, 0.45 µm, in bags	16D01--25-06--BK
Microsart® @filter, 250 ml, with cellulose nitrate membrane filter, white with black grid, 0.2 µm, in bags	16D01--25-07--BK
Microsart® @filter, 250 ml, with cellulose nitrate membrane filter, green with dark green grid, 0.45 µm, in bags	16D02--25-06--BK
Microsart® @filter, 250 ml, with cellulose nitrate membrane filter, white with black grid, 0.45 µm high flow, in bags	16D01--25-06--BK
Microsart® @filter, 250 ml, with cellulose nitrate membrane filter, gray with white grid, 0.65 µm, in bags	16D03--25-05--BK
Microsart® @filter, 250 ml, with cellulose nitrate membrane filter, gray with white grid, 0.45 µm high flow, in bags	16D03--25-H6--BK
Microsart® @filter, 250 ml, with cellulose nitrate membrane filter, white with black grid, 0.45 µm high flow, single sterile	16D01--25-H6-ACF
Microsart® @filter, 250 ml, with cellulose nitrate membrane filter, white with black grid, 0.2 µm, single sterile	16D01--25-H7-ACF
Microsart® @filter, 250 ml, with cellulose nitrate membrane filter, gray with white grid, 0.45 µm high flow, single sterile	16D03--25-H6-ACF

## 15.2.4 Biosart® 100 Monitors

Item	Order number
BS 100 Monitor, cellulose nitrate membrane filter, white with black grid, 0.45 µm, in trays	16401-47-06----K
BS 100 Monitor, cellulose nitrate membrane filter, white with black grid, 0.2 µm, in trays	16401-47-07----K
BS 100 Monitor, cellulose nitrate membrane filter, white with black grid, 0.45 µm high flow, in trays	16401-47-H6----K
BS 100 Monitor, cellulose nitrate membrane filter, green with dark green grid, 0.45 µm, in trays	16402-47-06----K
BS 100 Monitor, cellulose nitrate membrane filter, gray with white grid, 0.8 µm, in trays	16403-47-04----K
BS 100 Monitor, cellulose nitrate membrane filter, gray with white grid, 0.45 µm, in trays	16403-47-06----K
BS 100 Monitor, cellulose nitrate membrane filter, white with black grid, 0.45 µm, single sterile packaging	16401-47-06--ACK
BS 100 Monitor, cellulose nitrate membrane filter, white with black grid, 0.2 µm, single sterile packaging	16401-47-07--ACK
BS 100 Monitor, cellulose nitrate membrane filter, green with dark green grid, 0.45 µm, single sterile packaging	16402-47-06--ACK
BS 100 Monitor, cellulose nitrate membrane filter, gray with white grid, 0.45 µm, single sterile packaging	16403-47-06--ACK
BS 100 Monitor, cellulose nitrate membrane filter, white with black grid, 0.45 µm high flow, in box	16401-47-H6-V--K
BS 100 Monitor, cellulose nitrate membrane filter, white with black grid, 0.45 µm, in box	16401-47-06-V--K
BS 100 Monitor, cellulose nitrate membrane filter, gray with white grid, 0.8 µm, in box	16403-47-04-V--K
BS 100 Monitor, cellulose nitrate membrane filter, gray with white grid, 0.45 µm, in box	16403-47-06-V--K

### 15.2.5 Biosart® 250 Funnels

Item	Order number
Biosart® 250 Funnel, sterile	16407--25----ALK

### 15.2.6 Membrane Filters

Item	Order number
Cellulose nitrate, white with black grid, sterile, 0.45 µm, 47 mm, 100 pcs	11406--47----ACN
Cellulose nitrate, white with black grid, sterile, 0.45 µm, 47 mm, 1000 pcs	11406--47----ACR
Cellulose nitrate, white with black grid, sterile, 0.45 µm, 50 mm	11406--50----ACN
Cellulose nitrate, white with black grid, sterile, 0.45 µm, 47 mm, dispenser	11406Z-47----SCM
Cellulose nitrate, white with black grid, sterile, 0.45 µm, 50 mm, dispenser	11406Z-50----SCM
Cellulose nitrate, white with black grid, sterile, 0.45 µm high flow, 47 mm, 100 pcs	114H6--47----ACN
Cellulose nitrate, white with black grid, sterile, 0.45 µm high flow, 47 mm, 1000 pcs	114H6--47----ACR
Cellulose nitrate, white with black grid, sterile, 0.45 µm high flow, 47 mm, dispenser	114H6Z-47----SCM
Cellulose nitrate, white with black grid, sterile, 0.45 µm high flow, 50 mm, dispenser	114H6Z-50----SCM

### 15.3 Spare Parts

This table contains an excerpt of spare parts that can be ordered. For information on other products, contact Sartorius.

<b>Item</b>	<b>Order number</b>
Blind coupling for locking the manifold	168SP-A0001
Base support for the use of Microsart® funnels, Microsart® @filter units and Biosart® 100 monitors	168ZA-A0001
Sintered frit for the base support 168ZA-A0001	1ZU---0001
Base support for the use of Biosart® 250 funnels and stainless-steel funnels	168ZA-B0001
Sintered frit for base support 168ZA-B0001	6980102
Silicone gasket under the frit of the Base support 168ZA-B0001	6980124
PTFE gasket under the frit of the Base support 168ZA-B0001	6980104
Adapter for Biosart® 100 monitors	16424
Plug for sealing the ventilation hole	6980225
100 ml stainless-steel funnel	6981065
Cover for 100 ml stainless-steel funnel	6981063
Silicone seal for cover of 100 ml stainless-steel funnel	6981064
500 ml stainless-steel funnel	6981002
Cover for 500 ml stainless-steel funnel:	6981003
Silicone seal for cover of 500 ml stainless-steel funnel	6981003



Sartorius Lab Instruments GmbH & Co. KG  
Otto-Brenner-Strasse 20  
37079 Goettingen, Germany

Phone: +49.551.308.0  
www.sartorius.com

The information and figures contained in these instructions correspond to the version date specified below.

Sartorius reserves the right to make changes to the technology, features, specifications and design of the equipment without notice. Masculine or feminine forms are used to facilitate legibility in these instructions and always simultaneously denote the other gender as well.

Copyright notice:

This instruction manual, including all of its components, is protected by copyright. Any use beyond the limits of the copyright law is not permitted without our approval. This applies in particular to reprinting, translation and editing irrespective of the type of media used.

© Sartorius Germany

Last updated:  
02 | 2019